

## Diesel Generator Set Specifications Sheet- 200 kVA

Generator Specifications:	
Genset Manufacturer	Greaves Power
Genset Rating	Prime Power
Genset Output ( KVA / KW)	200 / 160
Genset Model	GPWII-P11-200
Engine rating or Max. Power at rated RPM, in KW (BHP)	178.8 (243.1)
Engine Model	6G11TAG29
Engine Type	TCAC
No. of Cylinders / Cylinder arrangement	6 / Inline
Displacement (L)	7.31
Bore & Stroke (mm)	108 X 133
Compression ratio	16.8
Rated RPM	1500
Governor: Type /Class of Governing	Mechanical/G2
Over speed trip (rpm)	1650
Air cleaner type / Qty	Dry / 01
Exhaust system	
Maximum allowable back pressure, kPa	5.5

Engine Electrical system:	
Charging alternator Voltage / Current (DC)	12V / 35Amps
Starter Motor rated voltage (DC)	12
Battery Voltage (DC) / Capacity (AH)	12V, 120AH

Fuel System:	
Recommended Fuel	HSD
Fuel tank capacity ( Ltr)	360
<b>Fuel consumption - LPH at % load</b>	
100%	45.1
75%	33.6
50%	23.8
25%	12.6

Lubricating Oil system :	
Lub oil sump capacity	17
Oil change period (Hrs)	500
Oil consumption (% of sfc)	≤ 0.2
Oil filter quantity (Nos) /type	01 / spin on type
Recommended Oil Grade	15W40 Greaves Maxtherm API C14
Oil Cooler	Water cooled

Cooling System :	
Cooling system is designed for max ambient temp, Deg. C at rated load	50
Radiator System capacity, including engine, (L)	40 Ltr
Water pump type	Centrifugal, Gear Driven

Alternator Specification:	
Voltage	380-440V
Frequency	50Hz
Current @ 0.8PF (Amps)	278.2
Type	4 Pole , Rotating field
Exciter Type	Brushless (Permanent magnet optional)
Leads: Quantity , type	6, fixed. 12, re connectable(Optional)
Voltage regulator	Solid State
Insulation	Class H ,
Temperature rise	125 Deg. C (Class H)
Bearing: Quantity , type	1, Sealed
Coupling	Flexible disc Closed Coupled
Voltage regulation : No load to full load	2 Phase sensing, ±1%
One step load acceptance	100% of rating
Unbalance load capability	25% of rated current

### Standard scope of supply:

**Engine** with direct injection, water cooled engine, 6 cylinder, in-line, 4 stroke, rated at 1500 RPM, conforming to **ISO 3046 / BS 5514** has the following specifications:

- Mechanical FIP
- Mechanical governor / Electronic Governor (Optional)
- Turbocharger, exhaust manifold, stainless steel exhaust flexible connection
- Radiator cooled with turbocharged after cooled
- Plate type lube oil cooler
- Filter –fuel, lube oil
- Dry type replaceable paper element air cleaner
- Flywheel housing and flywheel to suit single bearing alternator
- Starting motor – Electric, battery charging alternator
- First fill lube oil and coolant

**Alternator:** Meccalte / (Optional -Stamford/ Crompton Greaves /equivalent)

- brushless alternator
- Self-excited, self-regulated
- Class 'H' insulation limited to temperature rise of class H
- Salient pole revolving field
- Single bearing
- Automatic voltage regulator

**Acoustic enclosure** – Engine alternator assembly mounted on AVM with Silencer and S.S exhaust bellow suitably optimized to meet stringent sound & emission standards as laid down by MOEF / CPCB

- Base rail with draw-out type fuel tank is provided with a drain plug, air Vent inlet and outlet connections, level indicator, manhole etc.
- Sub-base fuel tank with 10 hours capacity
- 12 V dry, batteries with connecting leads and terminals
- 90% gloss RAL9003 white pure polyester powder coated, base in black colour.

**Control panel:** RAL 9003 White Powder coated control panel manufactured with CRCA sheet , Control Panel is having following features:

- Water and lube oil drain outlets located on the outer surface- Leading to ease of maintenance and cleanliness.
- MCCB of suitable rating with **short circuit** protection
- Controller which displays **voltage, current, KW, PF, Frequency, KWh**.
- Indicating lamps for "**Load On**" and "**Set Running**"
- **Current transformers** of suitable ratings
- **Aluminum busbars** of suitable capacity with incoming and Outgoing terminations
- Control fuses duly wired and ferruled

**Power cables:** Uninyvin copper conductor cables between Alternator & Control panel inside the canopy.

### Literature:

- Operation Manual
- General maintenance & installation Guideline
- Foundation Drawing
- Parts manual

### Generator Controller (GCU 6120-MKII)

CONTROLLER TYPE	FEATURES	DISPLAY PARAMETER	AUDIO VISUAL WARNING	SHUT DOWN WITH AUDIO VISUAL ANNUNCIATION
 <p><b>GCU 6120-MKII</b></p>	Compact and microprocessor based fully configurable control Unit.	Engine Oil pressure	Low Oil pressure	Low Oil Pressure
	4 line LCD display	Coolant temperature	High Coolant temperature	High Coolant temperature
	The unique integrated DG set controller	Fuel level indication %	Low Battery Voltage	Engine Over speed
	Incorporate both engine and alternator parameter in one console	Battery voltage	Low fuel Level	Engine Under speed
	Fully configurable digital out put	Engine rpm		Low Fuel Level
	All parameter are settable and password protected	DG set Running Hours		Over load
	AMF Ready	Generator Volts – Phase – Neutral & Phase - Phase		Under voltage
Remote start	Generator Current (Amps)		Over voltage	
	Power factor		Over frequency	
	KWHR		Under frequency	
	KW		Low Coolant level	
			High Canopy Temperature	

#### Optional Items:

**Cooling System:** Heater Kit for -20 Deg. C Operation / Heater Kit for -30 deg.Cel

**Electrical Systems:** Alternator Space Heater / Higher Rating Battery / Battery Charger / Battery Heater / Copper Bus Bar / Sealable kWh / Earth Fault Relay / Remote Annunciator / Remote monitoring / RTD/BTD Temperature Scanner.

**AMF & Synchronizing System:** AMF panel / AMF with Auto-synchronization (Deep Sea / Woodward)

**Open Unit (For Export)** Exhaust Silencer - Hospital / Residential grade, stainless steel, flexible pipe.

**Fuel System:** Flexible Fuel Lines / SS fuel lines / Fuel Pressure Gauge/ Fuel Flow meter.

**Enclosed Unit:** Sound Enclosure – Super silent / External 990 Lt. Fuel Tank.

**Miscellaneous:** Air Cleaner (Heavy Duty)/Air Cleaner Restriction Indicator Digital / Closed crankcase ventilation

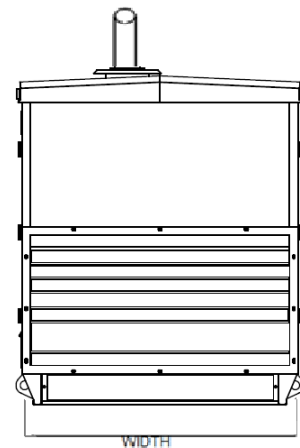
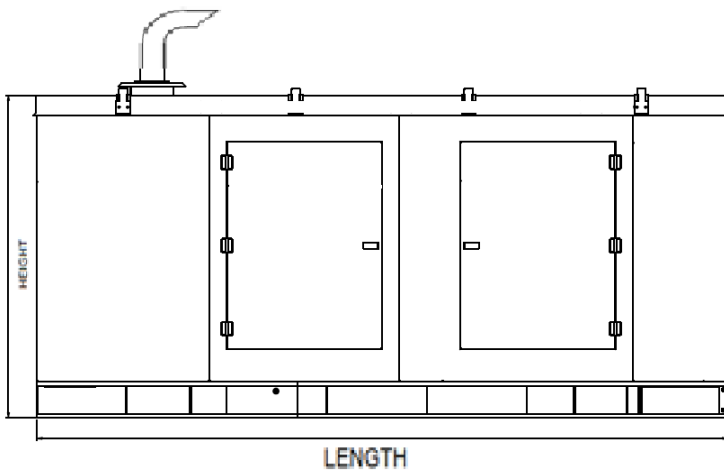

Typical Enclosed GENSET Dimensions & weight					
Model	Rating	Length(mm)	Width(mm)	Height(mm)	Dry Weight(kg)
GPWII-P11-200	200	4000	1600	1900	2300