

Diesel Generator Set Specifications Sheet- 30 kVA

Generator Specifications:	
Genset Manufacturer	Greaves Power
Genset Rating	Prime Power
Genset Output (KVA / KW)	30 / 24
Genset Model	GPWII-P11-30X
Engine rating or Max. Power at rated RPM, in KW (BHP)	31.2 (42)
Engine Model	G-30-II
Engine Type	TCAC
No. of Cylinders / Cylinder arrangement	3 / Inline
Displacement (L)	2.14
Bore & Stroke (mm)	91X110
Compression ratio	17.5
Rated RPM	1500
Governor: Type /Class of Governing	Mechanical/G2
Over speed trip (rpm)	1650
Air cleaner type / Qty	Dry / 01
Exhaust system	
Maximum allowable back pressure, kPa	5.5

Engine Electrical system: 50 Hz	
Charging alternator Voltage / Current (DC)	12V / 35Amps
Starter Motor rated voltage (DC)	12
Battery Voltage (DC) / Capacity (AH)	12V,88 AH

Fuel System:	
Recommended Fuel	HSD
Fuel tank capacity (Ltr)	75
Fuel consumption - LPH at % load	
100%	7.4
75%	5.9
50%	4.7
25%	3

Lubricating Oil system :	
Lube oil sump capacity	6.5
Oil change period (Hrs)	500
Oil consumption (% SFC)	≤0.1
Oil filter quantity (Nos) /type	01 / spin on type
Recommended Oil Grade	15W40 Greaves Maxtherm API C14
Oil Cooler	Water cooled

Cooling System :	
Cooling system is designed for max ambient temp, Deg. C at rated load	50
Radiator System capacity, including engine, (L)	12.5 Ltr
Water pump type	Engine mounted

Alternator Specification:	
Voltage	380-440V
Frequency	50Hz
Current @ 0.8PF (Amps)	130/41.7
Type	4 Pole , Rotating field
Exciter Type	Brushless
Leads: Quantity , type	6, fixed. 12, re connectable (Optional)
Voltage regulator	Solid State,
Insulation	Class H ,
Temperature rise	125 Deg. C (Class H)
Bearing: Quantity , type	1,Sealed
Coupling	Flexible disc
Voltage regulation : No load to full load	2 Phase sensing,±1%
One step load acceptance	100% of rating
Unbalance load capability	25% of rated current

Standard scope of supply:

Engine with direct injection, water cooled engine, 3 cylinder, in-line, 4 stroke, rated at 1500RPM, conforming to **ISO 3046 / BS 5514** has the following specifications:

- Mechanical FIP
- Mechanical governor
- Turbocharger, exhaust manifold, stainless steel exhaust flexible connection
- Radiator Cooled, Low Temperature After cooling (LTA)
- Filters - fuel, lube oil
- Dry type replaceable paper element air cleaner
- Flywheel housing and flywheel to suit single bearing alternator
- Starting motor – Electric, battery charging alternator
- First fill lube oil and coolant

Alternator: Meccalte / (Optional -Stamford/ Crompton Greaves /equivale)

- brushless alternator
- Self-excited, self-regulated
- Class 'H' insulation limited to temperature rise
- Salient pole revolving field
- Single bearing
- Automatic voltage regulator

Acoustic enclosure–Engine alternator assembly mounted on AVM with Silencer and S.S exhaust bellow suitably optimized to meet stringent sound emission standards as laid down by MOEF / CPCB

- Base rail with draw-out type fuel tank is provided with a drain plug, air Vent inlet and outlet connections, level indicator, manhole etc.
- Sub-base fuel tank with 11 hours capacity at 75% load
- 12 V dry, batteries with connecting leads and terminals
- 90% gloss RAL9003 white pure polyester powder coated, base in black color.

Control panel: RAL 9003 white Powder coated control panel manufactured with CRCA sheet, control Panel is having following Features:

- MCCB of suitable rating with **short circuit** protection
- Controller which displays **voltage, current, KW, PF, Frequency, KWh.**
- Indicating lamps for "**Load On**" and "**Set Running**"
- **Current transformers** of suitable ratings
- **Copper Cable** of suitable capacity with incoming and Outgoing terminations
- Control fuses duly wired and ferruled

Power cables: Uninyvin **copper** conductor cables between Alternator & Control panel inside the canopy.

Literature:

- Operation Manual
- General maintenance & installation Guideline
- Foundation Drawing
- Parts manual

Generator Controller (GADC-321)

CONTROLLER TYPE	FEATURES	DISPLAY PARAMETER	AUDIO VISUAL WARNING	SHUT DOWN WITH AUDIO VISUAL ANNUNCIATION
Greaves Advance Digital Controller 	Compact and microprocessor based fully configurable control Unit.	Engine Oil pressure	Low Oil pressure	Low Oil Pressure
	Graphic display	Coolant temperature	High Coolant temperature	High Coolant temperature
	The unique integrated DG set controller	Fuel level indication %	Low Battery Voltage	Engine Over speed
	Incorporate both engine and alternator parameter in one console	Battery voltage	Low fuel Level	Engine underspend
	Fully configurable digital out put	Engine rpm		Low Fuel
	All parameter are setttable and password protected	DG set Running Hours		Over load
	Remote start	Generator Volts - Phase - Neutral & Phase - Phase		Under voltage
		Generator Current (Amps)		Over voltage
		Power factor		Over frequency
		KWHR		Under frequency
		KW		

Optional Items:

Cooling System: Heater Kit for -20 Deg. C Operation / Heater Kit for -30 deg.Cel

Electrical Systems: Alternator Space Heater / Higher Rating Battery / Battery Charger / Battery Heater / Copper Bus Bar / Sealable kWh / Earth Fault Relay / Remote Annunciator / Remote monitoring / RTD/BTD Temperature Scanner.

AMF & Synchronizing System: AMF panel / AMF with Auto-synchronization (Deep Sea / Woodward)

Open Unit (For Export) Exhaust Silencer - Hospital / Residential grade, stainless steel, flexible pipe.

Fuel System: Flexible Fuel Lines / SS fuel lines / Fuel Pressure Gauge/ Fuel Flow meter

Enclosed Unit:- Sound Enclosure – Super silent / External 990 Lt. Fuel Tank.

Miscellaneous: Air Cleaner (Heavy Duty)/Air Cleaner Restriction Indicator Digital / Closed crankcase ventilation.

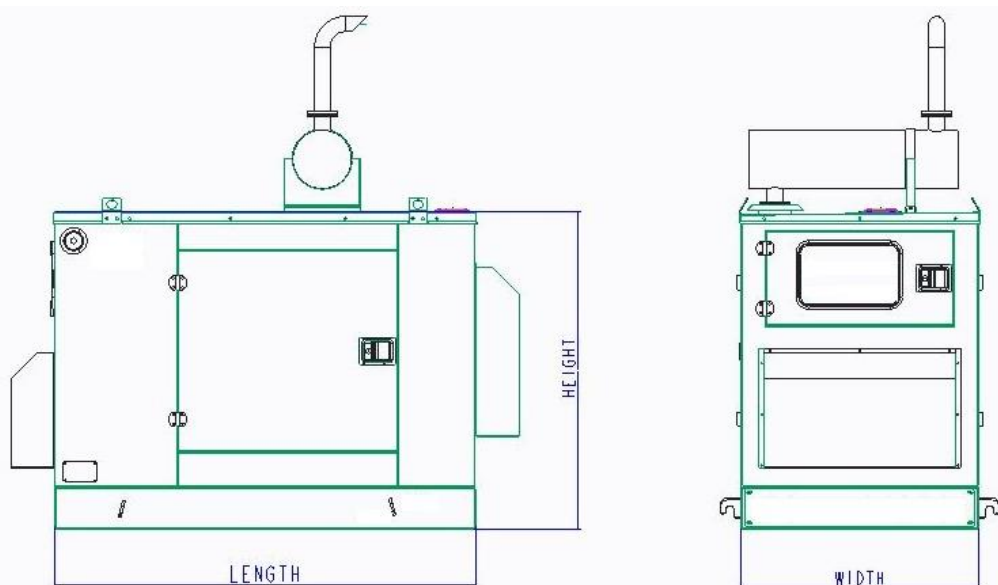

Typical Enclosed GENSET Dimensions & weight					
Model	Rating	Length(mm)	Width(mm)	Height(mm)	Dry Weight(kg)
GPWII-PII-30	30	1990	950	1335	1025